

# XT-150T Tri-Band Antenna Mount Amplifier



- **100 Watts, C-Band**  
**140 Watts, X-Band**  
**80 Watts, Ku-Band**
- **Low Cost Installation**
- **Short Waveguide Run**
- **Power Factor Corrected**
- **Optional Digital M&C Interface**

The XT-150T is a compact self-contained antenna mount power amplifier designed for low cost installation and long life.

Intended for outdoor operation, the XT-150T eliminates the need for a separate amplifier shelter.

In addition, the distance between the amplifier and the antenna feed horn can be short thus eliminating long waveguide runs and their associated RF losses.

Mounting brackets are supplied to mount the amplifier to most popular antennas.

A number of features have been incorporated to enhance overall reliability and minimize maintenance and replacement costs.

A high frequency resonant conversion power supply with power factor corrections is used that accepts a wide range of prime power (100 to 260 VAC).

A remote external controller is available to operate the HPA from a user selected location. The XT-150T may be configured for single thread, 1:1 or 1:2 redundant operation.

# PERFORMANCE SPECIFICATIONS

Parameter	C-Band	X-Band	Ku-Band
FREQUENCY RANGE	5.850 to 6.65 GHz	7.90 to 8.40 GHz	13.75 to 14.5 GHz
OUTPUT POWER			
Traveling Wave Tube	110 W	150 W	90 W
Rated Power @ Amplifier Flange	100 W	140 W	80 W
GAIN			
Large Signal, minimum	53 dB	53 dB	53 dB
Small Signal, minimum	57 dB	57 dB	57 dB
Maximum SSG Variation Over:			
Any Narrow Band	0.5 dB/10 MHz	0.5 dB/10 MHz	0.5 dB/10 MHz
Full Band	3.0 dB	2.5 dB	2.75 dB
Slope, maximum	±0.04 dB/MHz	±0.04 dB/MHz	±0.04 dB/MHz
Stability, 24 Hr maximum	± 0.25 dB	± 0.25 dB	± 0.25 dB
Stability, Temperature	± 1.0 dB maximum over temperature range at any frequency		
INTERMODULATION with two equal signals	-25 dBc maximum with two equal carriers at 7.5 dB total output backoff from rated power		
HARMONIC OUTPUT, maximum	-3 dBc max	-7 dBc max	-12 dBc max
AM/PM CONVERSION, maximum	2.5 deg/dB at 6 dB below rated power		
NOISE POWER, maximum			
Transmit Band	- 64 dBW/4 kHz	- 64 dBW/4 kHz	- 64 dBW/4 kHz
Receive Band	- 64 dBW/4 kHz 3.7 to 4.2 GHz	- 64 dBW/4 kHz 7.25 to 7.75 GHz	- 64 dBW/4 kHz 10.95 to 12.75 GHz
GROUP DELAY, maximum			
Bandwidth	Any 40 MHz	Any 40 MHz	Any 80 MHz
Linear	0.01 nS/MHz	0.01 nS/MHz	0.01 nS/MHz
Parabolic	0.005 nS/MHz <sup>2</sup>	0.005 nS/MHz <sup>2</sup>	0.005 nS/MHz <sup>2</sup>
Ripple	0.5 nS/Pk-Pk	0.5 nS/Pk-Pk	0.5 nS/Pk-Pk
RESIDUAL AM NOISE, maximum	- 50 dBc to 10 kHz - 20 (1.5 + logf) dBc 10 to 500 kHz - 85 dBc above 500 kHz		
PHASE NOISE, maximum	10 dB below IESS phase noise profile AC fundamental -50 dBc    Sum of all spurs -47 dBc		
VSWR			
Input, maximum	1.3:1	1.3:1	1.3:1
Output, maximum	2.2:1	2.2:1	2.2:1

## PRIME POWER

100-260 VAC  
47 to 63 Hz, single phase  
850 VA Maximum  
0.95 Minimum Prime Power Factor

## OPTIONS

Remote External Controller  
RS-232/485 Interface  
1:1, 1:2, 1:N Redundancy



## ENVIRONMENT

NONOPERATING TEMPERATURE RANGE	-50° C to + 70° C
OPERATING TEMPERATURE RANGE	-30° C to +60° C derated 2° C/1000 ft above 3000 ft
HUMIDITY	Up to 100% Condensing
ALTITUDE	10,000 feet MSL maximum
SHOCK	20g, 11ms
VIBRATION	4grms, 20-2000 Hz
COOLING	Forced Air

## INTERFACE

TYPE	FUNCTION		
CONTROLS	High Voltage ON/OFF	Heater Standby	Fault Reset
	<i>Note: Heater Standby reduces the TWT heater voltage for situations where the high voltage is off for extended periods.</i>		
MONITORS - DIGITAL	High Voltage ON	Filament Time Delay	Standby
	Helix Current/Arc Fault	Helix Latched Fault	Temperature Fault
	Summary Fault	High Voltage fault	Fan Fault
MONITORS - ANALOG	Helix Current (2 mA/V)	Cathode Voltage (1000:1 V/V)	
	TWT Temperature	RF Output Power (optional)	
AUXILIARY VOLTAGES	+15 VDC (100 MA max)		
	+24 VDC (100 MA max)		

# XT-150T

# Block Diagram

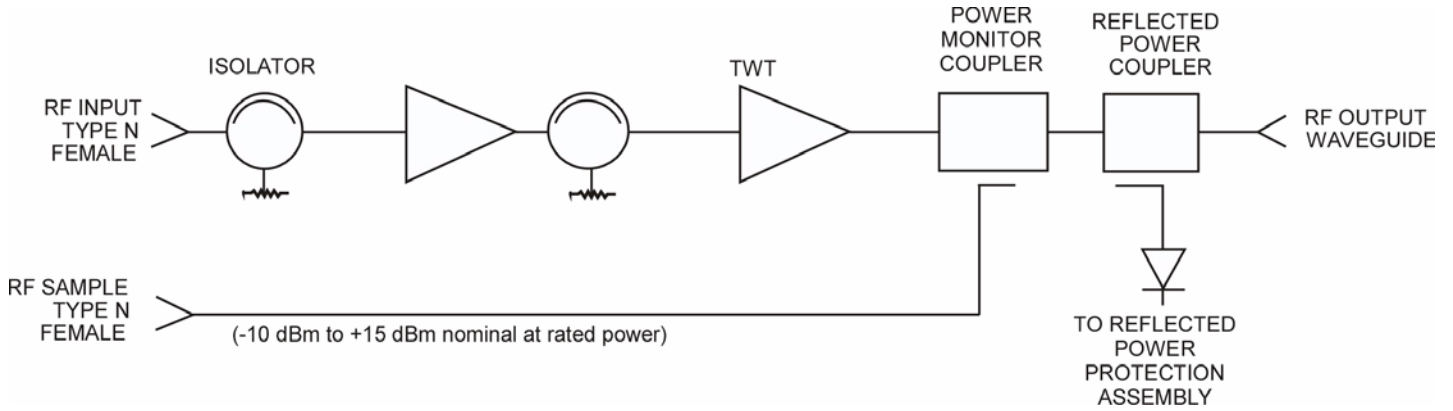

# Outline Drawing

