

# 100 Watt C, X, and Ku-Band Tri-Band Rack Mount High Power Amplifier



## FEATURES

- Power Factor Correction
- Digital Display & Control
- High Efficiency

The **XTRD-100T** is a highly efficient rack-mountable traveling wave tube (TWT) amplifier designed for fixed and mobile uplink applications. The unit includes RF gain control, a solid state pre-amplifier, RF filters, cooling, and monitoring & control (M&C) systems. Rack space is conserved because the amplifier occupies only 3 rack units (5 1/4 inches) of a standard 19 inch rack cabinet. Nominal weight is 50 pounds.

The unit features a menu driven front panel display, RS-232/422/485 serial port interfaces for complete computer control. RF, traveling wave tube, and default parameters are easily monitored on the four line front panel display. Gain control is provided via the front panel or through the serial interface.

The **XTRD-100T** amplifier incorporates high efficiency dual-stage collector TWTs. Reliability is enhanced because both prime power consumption and internal operating temperatures are reduced for both the linear and saturated modes of operation. Power factor correction circuitry is also included which minimizes line current distortion and reduces the required Volt-Amps input. The automatic features of the high frequency resonant conversion power supply include quick recovery from prime power supply outages and multiple helix fault resets (three fault cycles). Depending upon user requirements, this high power amplifier can be configured for either single thread or redundant system operation.



# PERFORMANCE SPECIFICATION

Parameters	C-Band	X-Band	Ku-Band
FREQUENCY RANGE	5.850 to 6.425 GHz*	7.90 to 8.40 GHz	14.0 to 14.5 GHz*
OUTPUT POWER			
Traveling Wave Tube	100 W	140 W	100 W
Rated Power @ Amplifier Flange	90	120 W	85 W
GAIN			
Large Signal (minimum)	57 dB	64 dB	57 dB
Small Signal (minimum)	62 dB	69 dB	62 dB
Attenuator Range (continuous)		20 dB	
Maximum SSG Variation Over			
Any Narrow Band	1.5 dB per 40 MHz	1.3 dB per 40 MHz	1.3 dB per 80 MHz
Full Band		± 2.5 dB	
Slope (maximum)		± 0.04 dB/MHz	
Stability, 24 hr. (maximum)		± 0.25 dB	
Stability, Temperature (maximum)	± 1.0 dB over temperature range at any frequency		
INTERMODULATION (maximum) with two equal carriers		-17 dBc @ 4 dB total output power backoff from rated power	
HARMONIC OUTPUT (maximum)	-3 dBc @ 49 dBm	-7 dBc	-12 dBc
AM/PM CONVERSION (maximum)	2.5 deg/dB at 6 dB below rated power		
NOISE POWER (maximum)			
Transmit Band		-70 dBW/4 kHz	
Receive Band	-70 dBW/4 kHz 3.7 to 4.2 GHz	-70 dBW/4 kHz 7.25 to 7.75 GHz	-70 dBW/4 kHz 10.95 to 12.75 GHz
GROUP DELAY (maximum)			
Bandwidth	Any 40 MHz	Any 40 MHz	Any 80 MHz
Linear		± 0.01 nS/MHz	
Parabolic		± 0.005 nS/MHz <sup>2</sup>	
Ripple		0.5 nS/Pk-Pk	
RESIDUAL AM NOISE (maximum)		-50 dBc to 10 kHz -20 (1.5 + logf) dBc 10 to 500 kHz -85 dBc above 500 kHz	
PHASE NOISE (maximum)		10 dB below IESS phase noise profile AC fundamental -50 dBc Sum of all spurs -45 dBc	
VSWR			
Input (maximum)		1.3:1	
Output (maximum)		2.2:1	

\* Extended frequency coverage available.

# BLOCK DIAGRAM

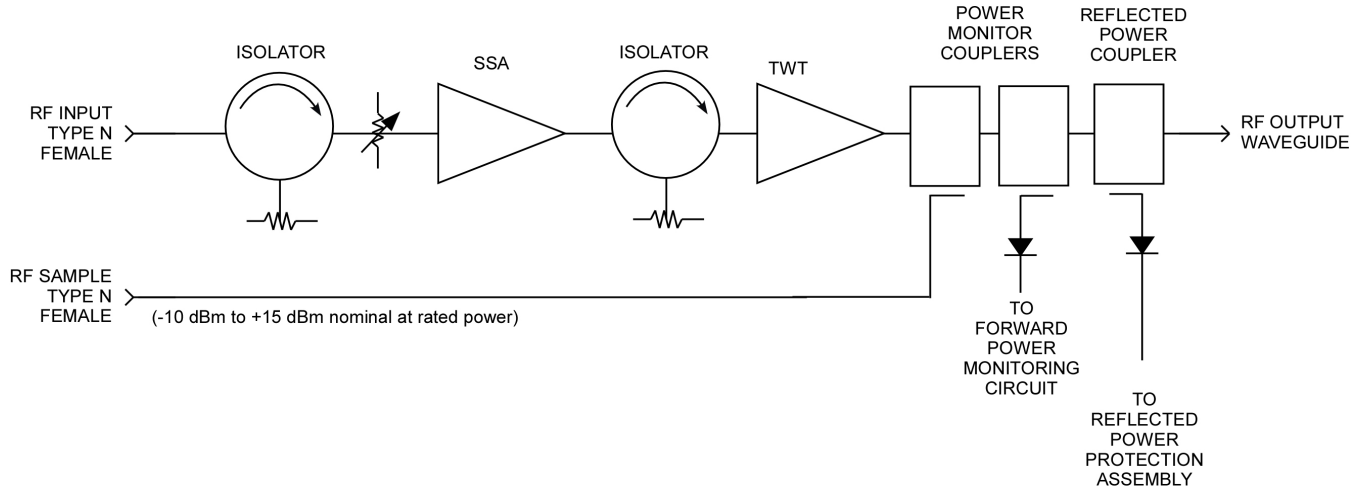

# OUTLINE DRAWING

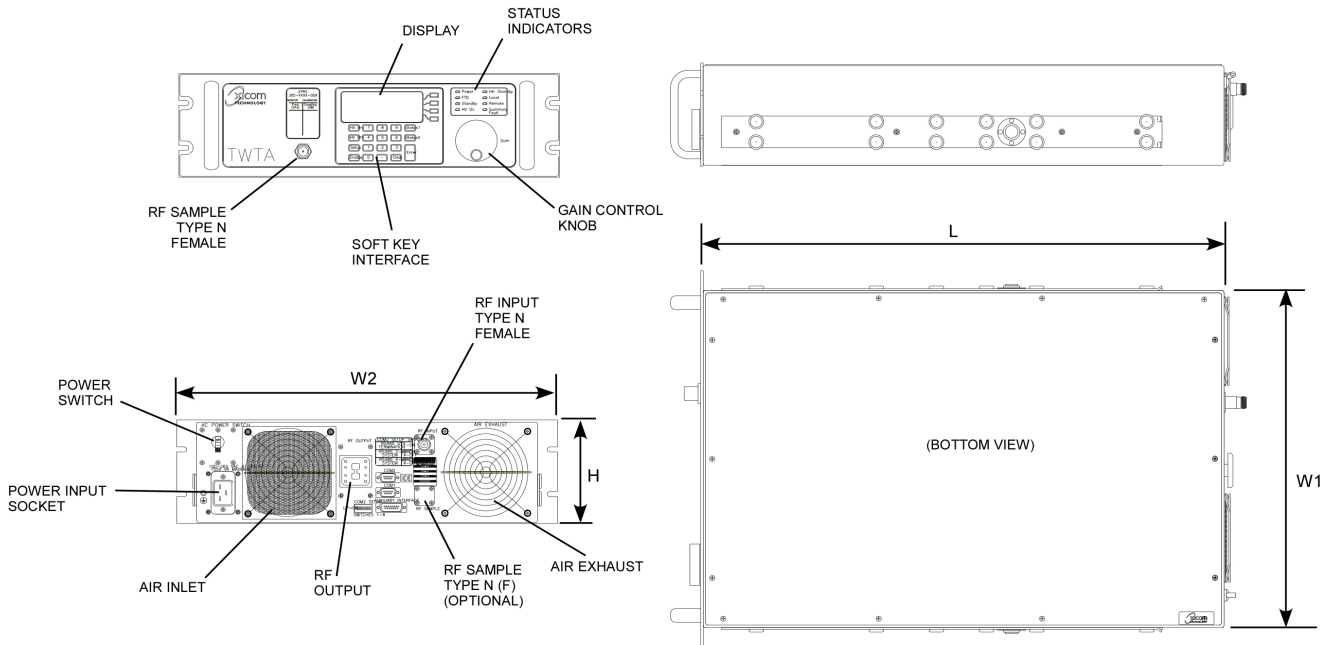

DIMENSIONS		
	INCHES	CENTIMETERS
L	26.00	66.04
W1	17.00	43.18
W2	19.00	48.26
H	5.219	13.26
Nominal Weight: 50 lbs (22.68 kg)		

## PRIME POWER

100 to 260 VAC  
47 to 63 Hz, Single Phase  
650 VA (maximum)  
0.95 Minimum Prime Power Factor



## ENVIRONMENT

NONOPERATING TEMPERATURE RANGE	-50°C to +70°C
OPERATING TEMPERATURE RANGE	-10°C to +50°C (2°C/1000 Feet Derating)
HUMIDITY	Up to 95% Noncondensing
ALTITUDE	10,000 Feet MSL (maximum)
SHOCK AND VIBRATION	Normal Transportation
COOLING	Forced Air

## INTERFACE

	Type	Function	
CONTROLS	LOCAL	Local/Remote	AC Power On/OFF
	LOCAL AND REMOTE	Gain	High Voltage ON/OFF
		Min/Max Power Alarm/Fault	Audio Alarm ON/OFF
		Reflected Power Alarm/Fault	Units (Watts, dBm, dBW)
		Fault Reset	Lamp Test
Heater Standby ON/OFF			
STATUS	FRONT PANEL LEDs	Standby	Power
		Local	Remote
		Summary Fault	High Voltage ON/OFF
		Heater Time Out (FTD)	Heater Standby
	FRONT PANEL DIGITAL DISPLAY	Power Out	Beam Hours
	Reflected Power	Helix Current	
	TWT Temperature	Helix Voltage	
	Heater Hours	Faults: High VSWR High Voltage Helix Current TWT Temperature	
COMPUTER SERIAL PORT	DRY FORM-C RELAY CONTACTS (2)	Summary Fault	
	HARDWARE INTERFACE	Two Ports: RS-232 & RS-422/RS-485	
	XICOM COMMAND SET	ASCII Commands	
	RF SAMPLE PORT COUPLING	-37 dB Nominal	

## OPTIONS

- Extended Frequency Coverage
- 1:1, 1:2, 1:N Redundancy
- Variable Phase Power Combining
- Integrated Linearizers

## Headquarters

Comtech Xicom Technology, Inc.  
3550 Bassett Street  
Santa Clara, CA 95054  
USA

Phone: +1-408-213-3000

Fax: +1-408-213-3001

email: [sales@xicomtech.com](mailto:sales@xicomtech.com)

Web: [www.xicomtech.com](http://www.xicomtech.com)

## Europe Sales Office

Comtech Xicom Technology Europe, LTD  
4 Portland Business Center  
Manor House Lane  
Datchet  
Berkshire SL3 9EG  
United Kingdom

Phone: +011 44 (0) 1753 549 999

Fax: +011 44 (0) 1753 549 997

email: [sales@xicomeurope.com](mailto:sales@xicomeurope.com)

Web: [www.xicomtech.com](http://www.xicomtech.com)

## Asia Sales Office

Comtech Xicom Technology  
150 Cecil Street  
#08-02  
Singapore 069543

Phone: +011 65 6325 1953

Fax: +011 65 6325 1950

email: [asiasales@xicomtech.com](mailto:asiasales@xicomtech.com)

Web: [www.xicomtech.com](http://www.xicomtech.com)

