

# 2250 Watt X-Band Rack Mount High Power Amplifier



## FEATURES

- Compact Size
- High Efficiency
- Digital Display and Control Interface
- Power Factor Correction
- Linearizer Option

**XTRD-2000X** digital rack-mount amplifier is designed for fixed and mobile uplink application. The high efficiency traveling wave tube amplifier includes RF gain control, a solid state pre-amplifier, RF filter, cooling, and a monitor & control (M&C) system. An integrated X-Band linearizer is available. The dual-drawer amplifier conserves rack space and occupies only 19.25 inches (11 rack units) of a standard 19 inch rack cabinet. A complete 1:1 or 1:2 redundant TWTA system, including a redundant controller, can be mounted in a single rack.

The **XTRD-2000X** features a menu-driven front panel display and RS-232 & RS-422/RS-485 serial port interfaces for complete remote control. Gain control is set by the front panel manual control or by computer commands sent via the remote interface(s).

The unit incorporates a high efficiency, multi-stage depressed collector TWT. Reliability is enhanced because both prime power consumption and internal operating temperatures are reduced for the linear and saturated modes of operation. The high frequency resonant conversion power supply is highly efficient and allows for quick recovery from prime power outages. Depending upon user requirements, the **XTRD-2000X** can be configured for single-thread, redundant, or phase combined operation.



# PERFORMANCE SPECIFICATION

Parameters	XTRD-2000X
FREQUENCY RANGE	7.90 to 8.40 GHz
OUTPUT POWER	
Traveling Wave Tube	2250 W
Rated Power @ Amplifier Flange (minimum)	2000 W
GAIN	
Large Signal (minimum)	70 dB
Small Signal (minimum)	75 dB
Attenuator Range (continuous)	25 dB
Maximum SSG Variation Over:	
Any Narrow Band	1.0 dB per 40 MHz
Full Band	2.5 dB
Slope (maximum)	± 0.04 dB/MHz
Stability, 24 hr. (maximum)	± 0.25 dB
Stability, Temperature (maximum)	± 1.0 dB over temperature range at any frequency
INTERMODULATION (maximum) with two equal carriers	-17 dBc @ 4 dB total output power backoff from rated power
HARMONIC OUTPUT (maximum)	-60 dBc
AM/PM CONVERSION (maximum)	2.5 deg/dB at 6 dB below rated power
NOISE POWER (maximum)	
Transmit Band	-70 dBW/4 kHz
Receive Band	-70 dBW/4 kHz 7.25 to 7.75 GHz
GROUP DELAY (maximum)	
Bandwidth	Any 40 MHz
Linear	± 0.01 nS/MHz
Parabolic	± 0.005 nS/MHz <sup>2</sup>
Ripple	0.5 nS/Pk-Pk
RESIDUAL AM NOISE (maximum)	-50 dBc to 10 kHz -20 (1.5 + logf) dBc 10 to 500 kHz -85 dBc above 500 kHz
PHASE NOISE (maximum)	10 dB below IESS phase noise profile AC fundamental -50 dBc Sum of all spurs -47 dBc
VSWR	
Input (maximum)	1.3:1
Output (maximum)	1.3:1

# BLOCK DIAGRAM

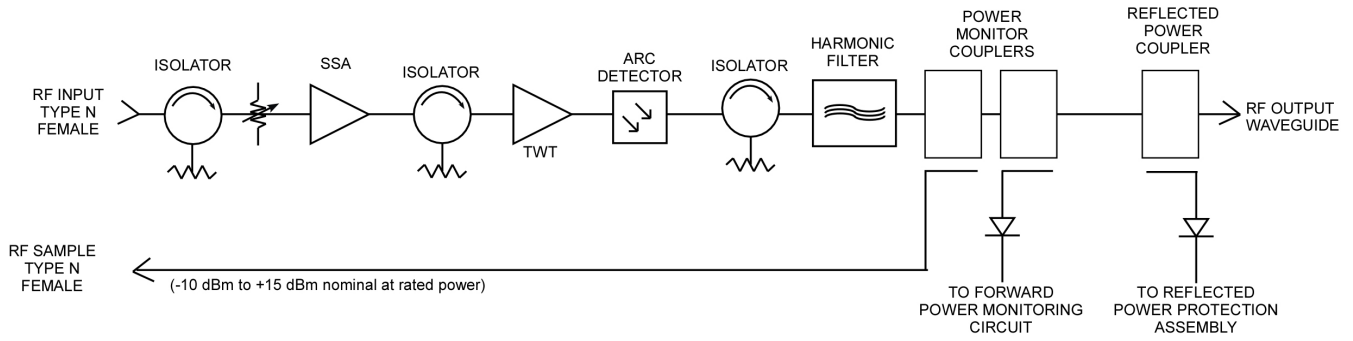

# OUTLINE DRAWING

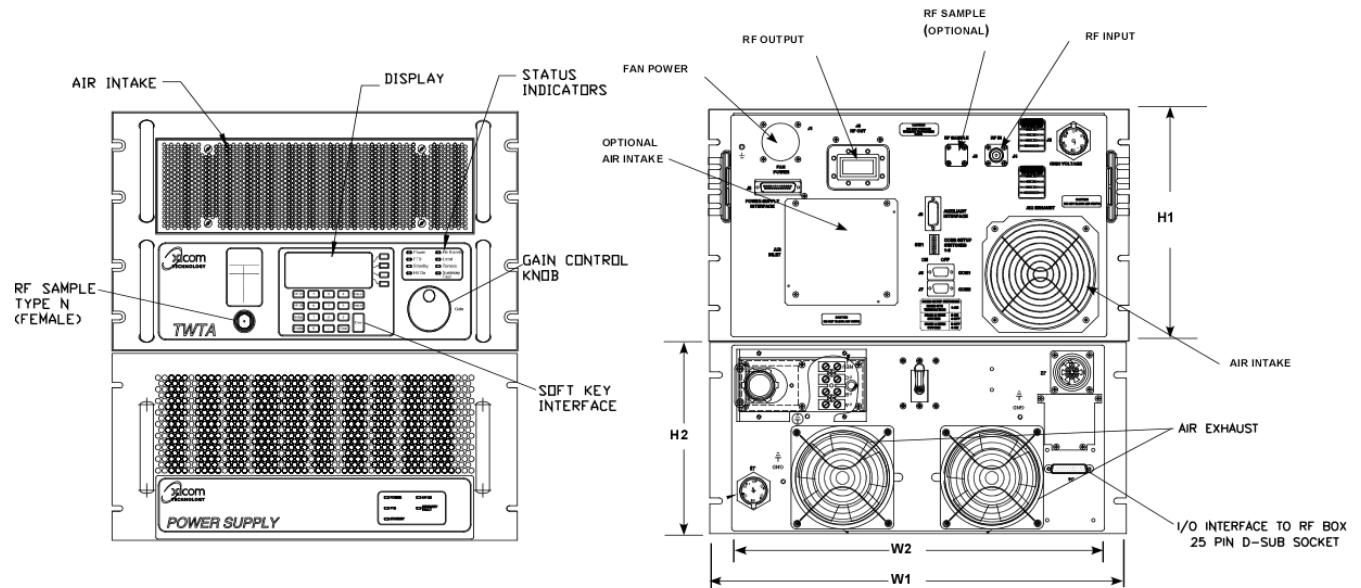

DIMENSIONS				
	INCHES	CENTIMETERS	INCHES	CENTIMETERS
W1	19.00	48.27	H1	10.09 25.63
W2	17.00	43.18	H2	8.72 22.15
RF OUTPUT: CPRG-112			NOMINAL WEIGHT = 230 lb (104.33 kg)	

## PRIME POWER

208 VAC ± 10% Three Phase, 4 Wire, 47 to 63 Hz  
7500 VA  
0.95 Minimum Prime Power Factor



## ENVIRONMENT

NONOPERATING TEMPERATURE RANGE	-50°C to +70°C
OPERATING TEMPERATURE RANGE	-10°C to +50°C (2°C/1000 Feet Derating)
HUMIDITY	Up to 95% Noncondensing
ALTITUDE	10,000 Feet MSL (maximum)
SHOCK AND VIBRATION	Normal Transportation
COOLING	Forced Air 275 CFM (typical)

## INTERFACE

	Type	Function		
CONTROLS	LOCAL	Local/Remote	AC Power On/OFF	
	LOCAL AND REMOTE	Gain	High Voltage ON/OFF	
		Min/Max Power Alarm/Fault	Audio Alarm ON/OFF	
		Reflected Power Alarm/Fault	Units (Watts, dBm, dBW)	
		Fault Reset	Lamp Test	
		Heater Standby ON/OFF	Frequency Select	
STATUS	FRONT PANEL LEDs	Standby	Power	
		Local	Remote	
		Summary Fault	High Voltage ON/OFF	
		Heater Time Out (FTD)	Heater Standby	
	FRONT PANEL DIGITAL DISPLAY	Power Out	Beam Hours	
		Reflected Power	Helix Current	
		TWT Temperature	Helix Voltage	
		Units Selection	Attenuator Setting	
		Heater Hours	Faults:	High VSWR
				High Voltage
		Helix Current		
		TWT Temperature		
	DRY FORM-C RELAY CONTACTS (2)	Summary Fault		
COMPUTER SERIAL PORT	HARDWARE INTERFACE	Two Ports: RS-232 & RS-422/RS-485		
	XICOM COMMAND SET	ASCII Commands		
	RF SAMPLE PORT COUPLING	-47 dB Nominal		

## OPTIONS

- 220/380 VAC ± 10% Three Phase, 5 Wire, 47 to 63 Hz
- 240/415 VAC ± 10% Three Phase, 5 Wire, 47 to 63 Hz
- 1:1, 1:2, 1:N Redundancy
- Variable Phase Combined
- Integrated Linearizers

## Headquarters

Comtech Xicom Technology, Inc.  
3550 Bassett Street  
Santa Clara, CA 95054  
USA

Phone: +1-408-213-3000

Fax: +1-408-213-3001

email: [sales@xicomtech.com](mailto:sales@xicomtech.com)

Web: [www.xicomtech.com](http://www.xicomtech.com)

## Europe Sales Office

Comtech Xicom Technology Europe, LTD  
4 Portland Business Center  
Manor House Lane  
Datchet  
Berkshire SL3 9EG  
United Kingdom

Phone: +011 44 (0) 1753 549 999

Fax: +011 44 (0) 1753 549 997

email: [sales@xicomeurope.com](mailto:sales@xicomeurope.com)

Web: [www.xicomtech.com](http://www.xicomtech.com)

## Asia Sales Office

Comtech Xicom Technology  
150 Cecil Street  
#08-02  
Singapore 069543

Phone: +011 65 6325 1953

Fax: +011 65 6325 1950

email: [asiasales@xicomtech.com](mailto:asiasales@xicomtech.com)

Web: [www.xicomtech.com](http://www.xicomtech.com)