

# 100 Watt Ku-Band Outdoor High Power SSPA



## FEATURES

- No Shelter Required
- Short Waveguide Run
- Low Cost Installation
- Removable Power Supply
- Complete Digital M&C Reference
- RS-232/422/485 Interface
- Built-in Redundancy Control

The **XTS-100K1** high power solid state power amplifier is a compact, fully integrated antenna-mount unit designed for low cost operation and longevity. Intended for outdoor operation, the **XTS-100K1** eliminates the need for a separate amplifier shelter. In addition, the distance between the amplifier and the antenna feed can be shorter, thus eliminating long waveguide runs and associated RF losses.

RF Filters, cooling, and monitor and control (M&C) systems are all self-contained within the package. A high frequency resonant conversion power supply is used that accepts a wide range of prime power (90 to 264 VAC). A remote external controller is available to operate the SSPA from a user-selected location.

Depending upon user requirements, these high power amplifiers can be configured for single thread, redundant, or phase combined configurations.

Mounting brackets are supplied to mount the high power amplifier to most popular antennas.



Field Replaceable Power Supply



# PERFORMANCE SPECIFICATION

Parameters	XTS-100K1	XTS-100K2
FREQUENCY RANGE, (extended frequency coverage available)	14.0 to 14.5 GHz	13.75 to 14.5 GHz
OUTPUT POWER		
Saturated Power (typical)	50 dBm	49 dBm
Rated Power (P1dB) @ Amplifier Flange	49 dBm	48 dBm
GAIN		
Small Signal (minimum)	60 dB, gain control set for maximum gain	
Small Signal (maximum)	70 dB, gain control set for maximum gain	
Gain Flatness (maximum)	2.5 dB	
Maximum SSG Variation	0.6 dB per 80 MHz	
Slope (maximum)	± 0.04 dB/MHz	
Stability, 24 hr. (maximum)	± 0.25 dB	
Stability, Temperature (maximum)	± 2.0 dB over temperature range at any frequency	
GAIN CONTROL	20 dB	
INTERMODULATION (maximum) with two equal carriers	-25 dBc @ P <sub>OUT</sub> = 40W	
SPECTRAL REGROWTH @ P <sub>OUT</sub> = 50W	-30 dBc, 1 symbol rate offset, OQPSK	
HARMONIC OUTPUT (maximum)	-60 dBc	
AM/PM Conversion (maximum)	2.5 deg/dB @ 3 dB below rated power	
NOISE POWER (maximum)		
Transmit Band	-80 dBW/4 kHz	
Receive Band	-150 dBW/4 kHz 10.95 to 12.75 GHz	
GROUP DELAY (maximum)		
Bandwidth	Any 80 MHz	
Linear	± 0.03 nS/MHz	
Parabolic	± 0.003 nS/MHz <sup>2</sup>	
Ripple	1 nS/Pk-Pk	
RESIDUAL AM NOISE (maximum)	-50 dBc to 10 kHz -20 (1.5 + logf) dBc 10 to 500 kHz -85 dBc above 500 kHz	
PHASE NOISE (maximum)	10 dB below IESS phase noise profile	
VSWR		
Input (maximum)	1.2:1	
Output (maximum)	1.3:1	

# BLOCK DIAGRAM

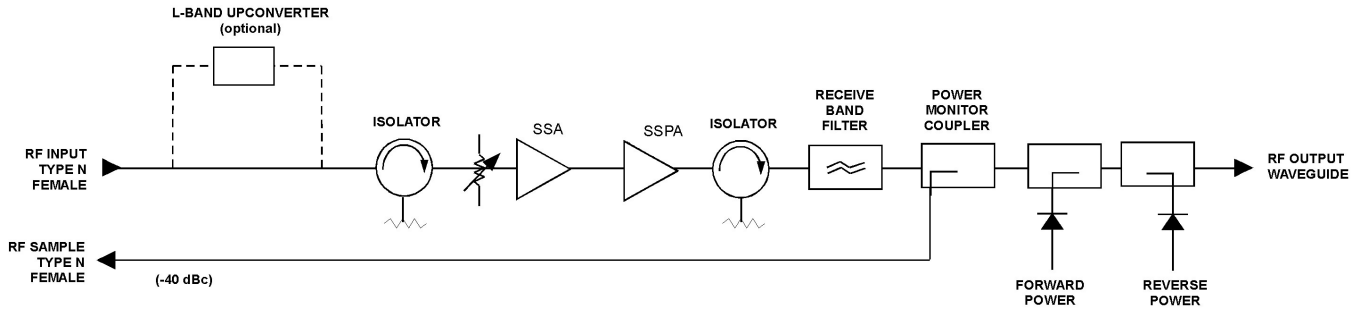

# OUTLINE DRAWING

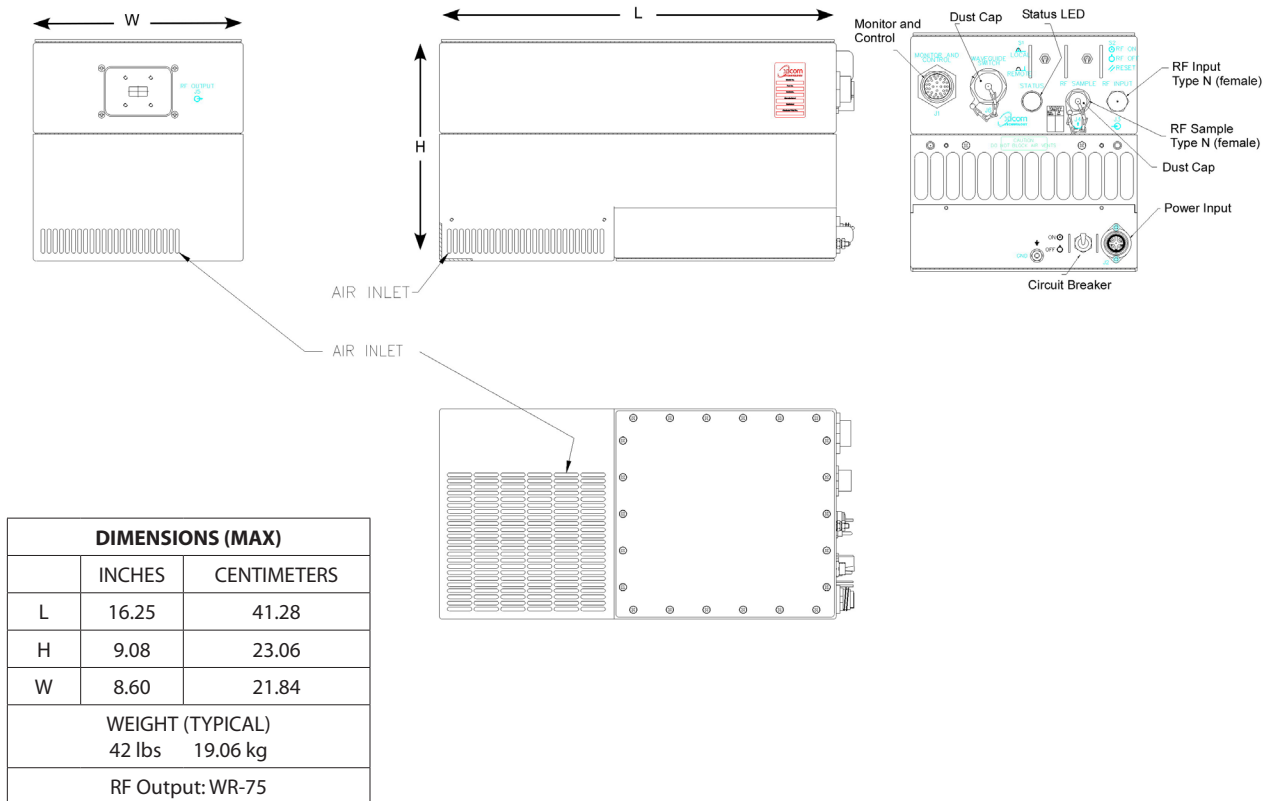

## PRIME POWER

90 to 264 VAC  
47 to 63 Hz, Single Phase  
950 VA (maximum)  
0.95 Minimum Prime Power Factor



## ENVIRONMENT

NONOPERATING TEMPERATURE RANGE	-50°C to +70°C
OPERATING TEMPERATURE RANGE	-40°C to +50°C (2°C/1000 Feet Derating)
HUMIDITY	Up to 100% Condensing
ALTITUDE	12,000 Feet MSL (maximum)
SHOCK AND VIBRATION	Normal Transportation
COOLING	Forced Air

## INTERFACE

Type	Function	
LOCAL CONTROL	Prime Power ON/OFF	Local/Remote
	Power Supply ON/OFF	Transmit ON/OFF
LOCAL STATUS	Tri-Color LED:	
	Fault: Red	Standby: Continuous Amber
	Transmit ON: Green	
REMOTE CONTROL	Transmit ON/OFF	RF Inhibit (HV OFF)
	RF Attenuation	Fault Reset
	Summary Fault	Constant Power
REMOTE STATUS	Transmit ON	Transmit/Standby Hours
	RF Output Power	Fault Identification
	Reflected Power	Temperature
FORM C DRY CONTACT CLOSURE	Summary Fault	
XICOM COMMAND SET	ASCII Commands	
RF MONITOR PORT	-40 dB Coupling Value (Nominal)	

## OPTIONS

- Built-in L-Band Block Upconverter (Option B1)
- Internal 10 MHz BUC Reference (Option R1)
- Ethernet Interface

## Headquarters

Comtech Xicom Technology, Inc.  
3550 Bassett Street  
Santa Clara, CA 95054  
USA

Phone: +1-408-213-3000

Fax: +1-408-213-3001

email: [sales@xicomtech.com](mailto:sales@xicomtech.com)

Web: [www.xicomtech.com](http://www.xicomtech.com)

## Europe Sales Office

Comtech Xicom Technology Europe, LTD  
4 Portland Business Center  
Manor House Lane  
Datchet  
Berkshire SL3 9EG  
United Kingdom

Phone: +011 44 (0) 1753 549 999

Fax: +011 44 (0) 1753 549 997

email: [sales@xicomeurope.com](mailto:sales@xicomeurope.com)

Web: [www.xicomtech.com](http://www.xicomtech.com)

## Asia Sales Office

Comtech Xicom Technology  
150 Cecil Street  
#08-02  
Singapore 069543

Phone: +011 65 6325 1953

Fax: +011 65 6325 1950

email: [asiasales@xicomtech.com](mailto:asiasales@xicomtech.com)

Web: [www.xicomtech.com](http://www.xicomtech.com)